

Series 994, 994RPDA

Reduced Pressure Zone Assemblies

Reduced Pressure Detector Assemblies

Sizes 2 1/2" – 10"

Repair Kits

When ordering specify Ordering Code, Kit No., and Valve Size.

ORDERING CODE	KIT NO.	SIZE
---------------	---------	------

First Check Kits

LEAD FREE	ORDERING CODE	KIT NO.	SIZE
	0888830	RK 994/994 RPDA CK1	2 1/2", 3", 4"
	0888831	RK 994/994 RPDA CK1	6"
	0888832	RK 994/994 RPDA CK1	8", 10"

Kit consists of: complete No. 1 check with check O-ring.

Second Check Kits

LEAD FREE	ORDERING CODE	KIT NO.	SIZE
	0888833	RK 994/994 RPDA CK2	2 1/2", 3", 4"
	0888834	RK 994/994 RPDA CK2	6"
	0888835	RK 994/994 RPDA CK2	8", 10"

Kit consists of: complete No. 2 check with check O-ring.

Cover Kits

LEAD FREE	ORDERING CODE	KIT NO.	SIZE
	0888836	RK 994/994 RPDA C	2 1/2", 3", 4"
	0888837	RK 994/994 RPDA C	6"
	0888838	RK 994/994 RPDA C	8", 10"

Kit consists of: cover, grooved coupler, gasket.

Relief Valve Rubber Parts Kits

LEAD FREE	ORDERING CODE	KIT NO.	SIZE
	0888839	RK 994/994 RPDA RV	2 1/2" – 10"

Kit consists of: rubber disc, piston diaphragm assembly, disc retainer, relief valve body O-ring.

Relief Valve Total Kits

LEAD FREE	ORDERING CODE	KIT NO.	SIZE
	0888840	RK 994/994 RPDA VT	2 1/2" – 10"

Kit consists of: body, disc, piston diaphragm assembly, hex head bolt, disc retainer, sleeve, bottom bolt, shut-off plate and bottom flange.

Use 2 1/2" – 4" repair kits for repair of 994 BLT, 994 HMB

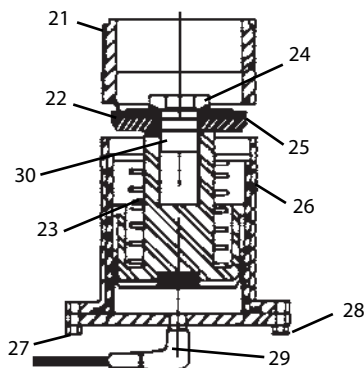

No. 1 Check 2 1/2" & 6"

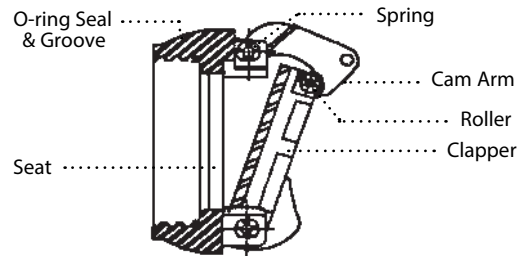

No. 1 Cam-Check 8" & 10"

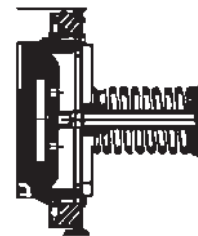

No. 2 Check 2 1/2" & 6"

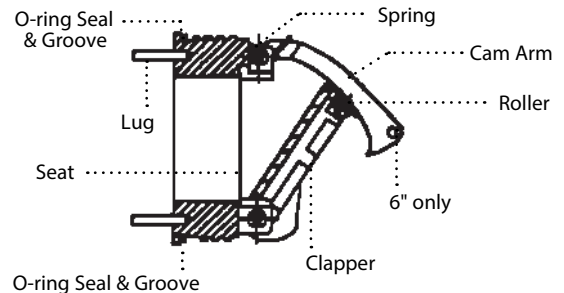

No. 2 Cam-Check 8" & 10"

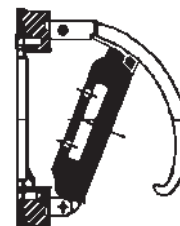

Parts Table

ITEM	PART DESCRIPTION	QTY.
21	Relief valve body	1
22	Rubber shutoff disc	1
23	Piston diaphragm assembly	1
24	Hex head bolt	1
25	Disc retainer	1
26	Sleeve	1
27	Bottom bolt	1
28	Bottom flange (w. st. elbow)	1
29	Bottom St. Elbow	1
30	O-ring disc	1

*The wetted surface of this product contacted by consumable water contains less than 0.25% of lead by weight.