



INSTALLATION, OPERATION & MAINTENANCE INSTRUCTIONS

1455 Kleppe Lane ♦ Sparks, NV 89431-6467 ♦ (775) 359-4712 ♦ Fax (775) 359-7424
E-mail: haws@hawsco.com ♦ website: www.hawsco.com

No. 0580001139 (1)

3690 WALL MOUNT CONFIGURATION Outdoor Bottle Filler

NOTE TO INSTALLER: Please leave this information with the Maintenance Department.

LIMITED WARRANTY

HAWS warrants that this specific product is guaranteed against defective material or poor workmanship for a period of **one year from date of shipment**. HAWS liability under this warranty shall be discharged by furnishing without charge F.O.B. HAWS Factory any goods, or part thereof, which shall appear to the Company upon inspection to be of defective material or not of first-class workmanship, provided that claim is made in writing to Haws within a reasonable period after receipt of the product. Where claims for defects are made, the defective part or parts shall be delivered to the Company, prepaid, for inspection. HAWS will not be liable for the cost of repairs, alterations or replacements, or for any expense connected therewith made by the owner or his agents, except upon written authority from HAWS, Sparks, Nevada. HAWS will not be liable for any damages caused by defective materials or poor workmanship, except for replacements, as provided above. Buyer agrees that HAWS shall not be liable for general, special, or consequential damages claimed to arise under the contract of sale. The drinking fountain manufactured by HAWS is warranted to function if installation and maintenance instructions provided are adhered to. The units also must be used for the purpose for which they were intended.

**NO OTHER WARRANTIES EXPRESSED OR IMPLIED ARE AUTHORIZED,
PROVIDED OR GIVEN BY HAWS.**

**SHOULD YOU EXPERIENCE DIFFICULTY WITH THE INSTALLATION OF THIS
MODEL PLEASE CALL:**

TECHNICAL SUPPORT: 1-800-766-5612

FOR CUSTOMER SERVICE: 1-888-640-4297

RECOMMENDED TOOLS:

- Measuring Tape
- PVC Pipe Cutter
- Plastic Tubing Cutter
- PVC Solvent Weld Glue
- ¼" Bit-Holding Screwdriver
- Level
- 10" Pipe Wrench
- Adjustable Plier
- 1/8 and 5/32 Tamper Resistant Hex Bits (Supplied)
- 9/16" Box/Open Combination Wrench, 8" Max Length
- 3/8" Socket Wrench/Ratchet, 8" Max Length
- 9/16" Deep Socket

LOCATION OF UNIT: The Model 3690 Outdoor Bottle Filler in Wall Mount configuration will protrude more than 4" from the wall. If the unit will not be mounted in an alcove, the unit should be mounted such that it does not exceed the 27" maximum cane detection height. When installing this unit, local, state and federal (including ADA) codes must be adhered to.

The supplied wall bracket is compatible with a Haws Model 6700 or 6700R (not supplied) mounting plate. This is recommended for use with framed walls if no solid blocking is available. Where appropriate solid blocking is available, use of 3/8" through bolting is recommended. See bracket drawing on page 5 for plumbing pass through location.

SUPPLY LINE: The minimum recommended line size is 1/2"IPS with 30-90 psi (2-6 ATM) flowing pressure. Where sediment or mineral content is a problem, an inlet filter is recommended.

PLUMBING CONNECTIONS: Water supply inlet connection is a 3/8"O.D. quick-connect fitting for the 3690 Bottle Filler. Waste outlet is 1-1/2" PVC pipe.

MAINTENANCE: For 3690 models- Periodically clean the pushbutton valve strainer. Refer to 5874 Series Valve Operation and Maintenance Sheet for more information.

INSTALLATION PROCEDURE

Follow the installation procedures outlined in the installation drawing below.

GENERAL NOTES:

1. **For all plastic push-in type fitting connections, only connect NSF-61 copper or plastic tubing. Stainless steel or glass tubing is not recommended. The following assembly instructions must be followed to ensure a watertight connection:**
 - a. **Cut tubing square and clean.**
 - b. **Mark from end of tube the length of insertion (See table below).**
 - c. **Push tube into the fitting until it bottoms out.**
 - d. **To remove, depress collet and pull tubing out**

Tube Sizes	O.D. Tolerance	Insertion Depth
3/8"	±.005"	3/4"

TROUBLESHOOTING	
PROBLEM	REPAIR CHECKLIST
1. Insufficient bottle filler flow	1a. Nozzle strainer is clogged. Use nozzle removal tool to remove strainer and replace. Replacement strainers may be ordered by calling Customer Service. b. For 3690- Check that inlet screwdriver stop valve is wide open. Clean inlet strainer or adjust valve to increase flow. See 5874 Series Valve Manual.*

*For more information about Haws products, see our website: www.hawSCO.com

REPLACEMENT PARTS

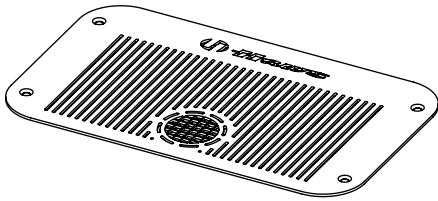

0410000564
BOTTLE FILLER DRAIN
COVER PLATE

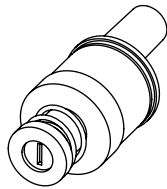

MODEL VRK5874HF
VALVE REPAIR KIT,
HIGH FLOW



MODEL VRKNOZ1
QTY 10 AERATORS
AND INSTALL TOOL

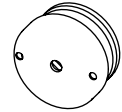

MODEL PBA7
BUTTON ASSEMBLY

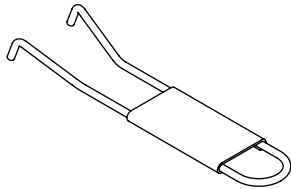

0006983506
SPANNER WRENCH

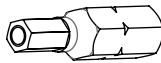

0510001030
HEX BIT,
PINNED, 5/32"

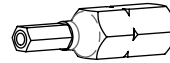

0510001029
HEX BIT,
PINNED, 1/8"

3690 WALL MOUNT CONFIGURATION

PARTS BREAKDOWN

WHEN ORDERING PARTS, PLEASE
SPECIFY PART NUMBER

			1455 KLEPPE LANE SPARKS, NEVADA 89431 (775) 359-4712 FAX (775) 359-7424 E-MAIL: HAWS@HAWS.CO.COM WEBSITE: WWW.HAWS.CO.COM	
ECN: 5636	REV. ECN: 5636	BY:	MODEL(S)	PART NUMBER
DRAWN: DHP	DATE: 6/11/20	CHKD: FV	3690 WALL MOUNT CONFIGURATION	0580001139
APPROVED: FV	DATE: 12/23/20	SCALE: 1:2	DRAWING TYPE: PARTS BREAKDOWN	REVISION 1
			SIZE: A	SHEET 1 OF 1

NOTES:

1. INSTALLER MUST UNDERSTAND AND ADHERE TO LOCAL, STATE, AND FEDERAL CODES AND REGULATIONS, INCLUDING THE AMERICANS WITH DISABILITIES ACT (ADA).
2. WALL BRACKET MAY BE INSTALLED IN CONCRETE/MASONRY, WITH APPROPRIATE IN-WALL BLOCKING, OR WITH HAWS IN-WALL MOUNTING PLATE MODEL 6700 (SOLD SEPARATELY - NOT SUPPLIED).
3. INSTALL THE WALL BRACKET WITH A LEVEL AND APPROPRIATE 3/8" DIAMETER HARDWARE USING ONE OF THE METHODS IN NOTE 2. IF NOT INSTALLED IN AN ALCOVE, THE ADA MAY REQUIRE THAT THE BOTTOM OF THE BRACKET BE A MAXIMUM OF 25-1/4" ABOVE THE FLOOR (27" BOTTOM OF FIXTURE) LEVEL FOR CANE DETECTION (SEE NOTE 1).
4. INSTALL SHORT ARM WITH QTY. 4 EACH 3/8" X 3/4" LONG BOLTS (SUPPLIED).
5. PLACE TRIM RING UNDER 3690 BOTTLE FILLER AND PLACE BOTTLE FILLER ON SHORT ARM.
6. INSTALL 4 EACH 3/8" X 1-1/4" LONG BOLTS (SUPPLIED) THROUGH HOLES IN BOTTOM OF BOTTLE FILLER AND MATCHING HOLES IN SHORT ARM.
7. CAREFULLY CENTER TRIM RING AND BOTTLE FILLER BEFORE INSTALLING FOUR 3/8" SERRATED FLANGE NUTS (SUPPLIED) ONTO BOLTS AND TIGHTENING.
8. INSTALL DRAIN AND SUPPLY PLUMBING THROUGH WALL AS REQUIRED.
9. SECURE BOTTOM SHORT ARM COVER TO BOTTOM OF SHORT ARM WITH 3 TAMPER RESISTANT BUTTON HEAD SCREWS (SUPPLIED).

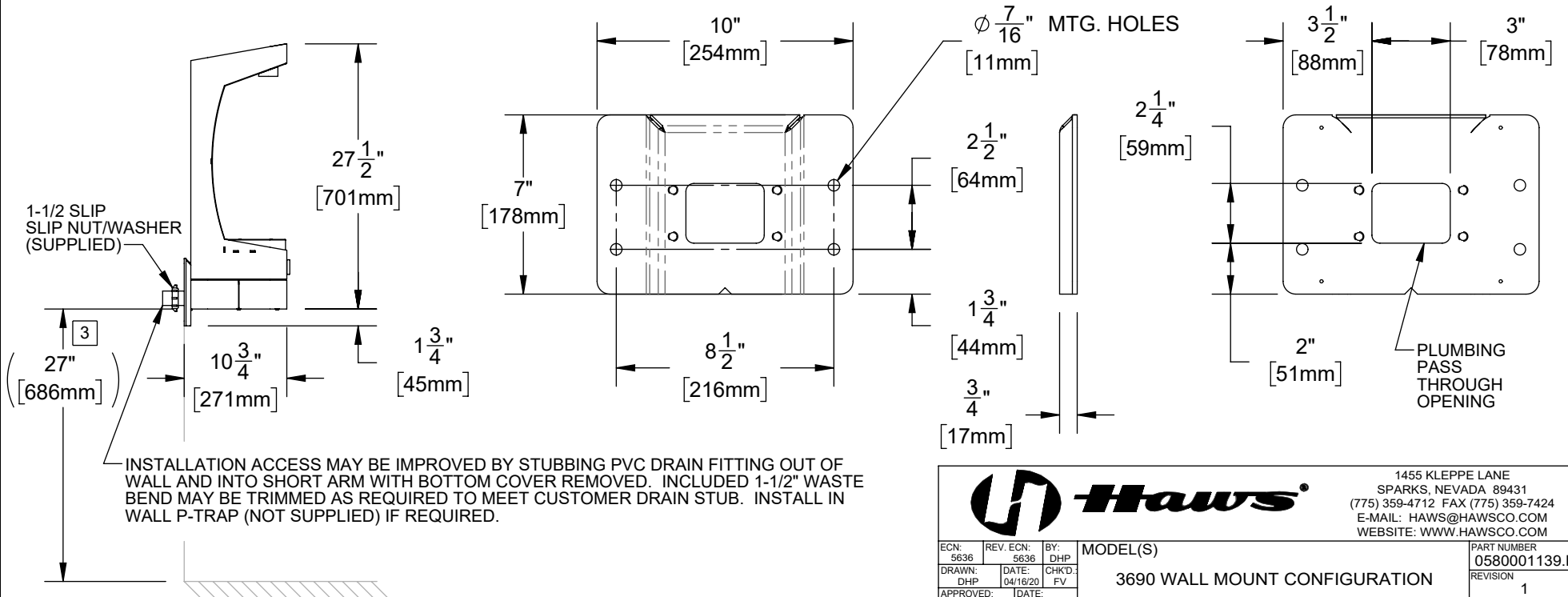
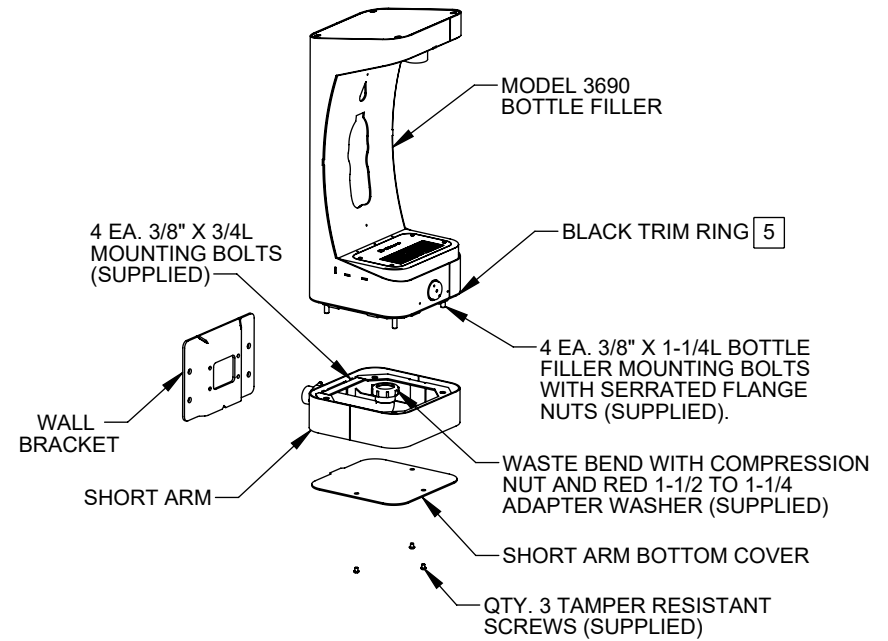

1455 KLEPPE LANE
 SPARKS, NEVADA 89431
 (775) 359-4712 FAX (775) 359-7424
 E-MAIL: HAWS@HAWSCO.COM
 WEBSITE: WWW.HAWSCO.COM

		MODEL(S) 3690 WALL MOUNT CONFIGURATION		PART NUMBER 0580001139.D	
ECN: 5636	REV. ECN: 5636	BY: DHP			
DRAWN: DHP	DATE: 04/16/20	CHKD: FV			
APPROVED: FV	DATE: 12/23/20	SCALE: 1:8	DRAWING TYPE: INSTALLATION	SIZE: A	SHEET 1 OF 1