



ISO 9001 Certified

## HB8SLE-128

1.28 GPF

Solar Powered Flush Valve (Closet)

### Description

Solar powered with battery backup, sensor operated, water conserving, closet flush valve for floor mounted or wall hung top spud bowls.

### Flush Cycle

- 1.28 GPF
  - \* Flush valves may not function with all bowls. Be sure to verify flow requirements with bowl manufacturer.
  - \* Flow rate is field adjustable.

### Specifications

Exposed, Piston Operated, Chrome Plated, Closet Flush Valve with the following features:

- Standard Brass/Chrome Plated All Metal Construction
- Superior, Slow-Closing, Piston Flushing Mechanism
- Standard Manual – True Mechanical Override Button
- Field Adjustable to Left or Right Rough-In
- Operating Pressures: 10-125 PSI
- Standard Self-Cleaning Filtering System
- Superior VSI Silicone Elastomer Piston Seals are Unaffected by Chlorine, Chloramines, and Ammonia
- ADA Compliant—Infrared Sensor Operated for “No Hands” operation
- Self-Diagnostic Electronics System with Manual Reset
- Reliable, Latching Solenoid Valve
- Preset / Adjustable Sensor Distance
- Adjustable Tailpiece
- 1” I.P.S. Angle Stop Valve with Vandal Resistant Cap
- High Back Pressure Vacuum Breaker / Flush Tube Connection
- Spud Coupling and Flange for 1-1/2” Top Spud
- Sweat Solder Adapter with Cover Tube and Wall Flange
- High Copper, Low Zinc Brass Casting for Dezincification Resistance
- 24-hour Sentinel Flush
- (4) AA Alkaline Batteries—Furnished

### Electrical Specifications

- Battery: (4) AA Alkaline Batteries
- Solenoid Valve and Sensor, 6V DC
- Battery Service Life: 650,000 flushes, up to 10 years

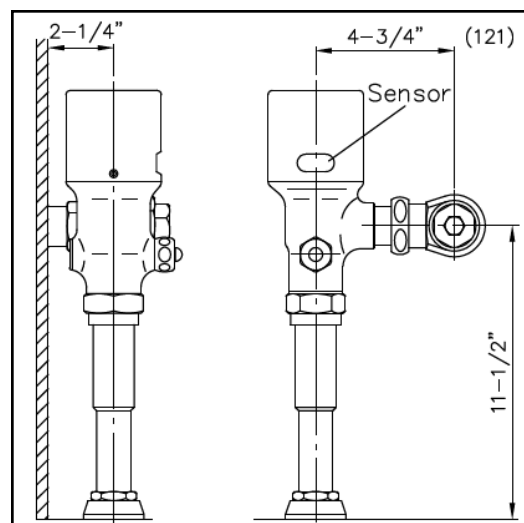

### **HYDROTEK INTERNATIONAL, INC.**

5055 Forsyth Commerce Rd., Ste. 124

Orlando, FL 32807

1.800.922.9883 (Phone)

1.866.670.5580 (Fax)

[www.hydrotekintl.com](http://www.hydrotekintl.com)

