

Maintenance Manual

Double Check and Double Check Detector Assemblies

Series 850, 856, 870V & 876V
2½" - 10" (65 – 250mm)

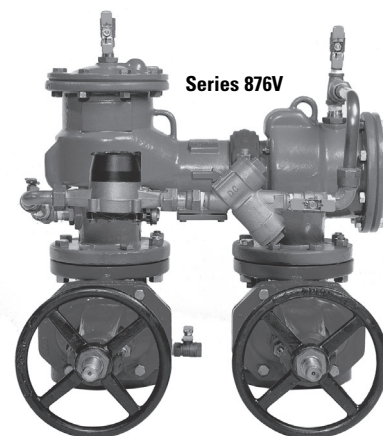

Table of Contents

Features and Operating Procedures	2
How to Order Parts	2
Trouble Shooting Guide	3
Vandalism	3
Testing	3
Freeze Protection Procedures	4
General Service Procedures	4
Service Procedures for Models 850, 856, 870V & 876V (2½" - 10")	6
Service Procedures for Model 805YB — ¾" Bypass	7
Parts Selection Guide Model 850/856 (2½" - 10")	8
Parts Selection Guide Model 870, 870V / 876, 876V (2½" - 10")	9
Parts Selection Guide	10-11

Read and understand this manual prior to installing, operating or servicing this equipment.

Feature and Operating Procedures

Double Check Valve Assembly Operation

The FEBCO Double Check Valve Assemblies consist of two independently operating, spring loaded check valves. The pressure drop across the first check valve is approximately 1.0 psig with no flow. The pressure drop across the second check valve is also 1.0 psig with no flow.

A complete assembly includes two shutoff valves and four test cocks.

NOTE: The 870V and 876V, when installed in the vertical orientation, must include vertical support under the second check body section.

Double Check Detector Assemblies Bypass Operation

All low flow demands up to a minimum of three GPM are to pass only through the bypass assembly.

All flows above three GPM will pass through both the bypass and main-line valve without accurate meter registration.

How to Order Parts/Repair Kits

- 1) Locate item number and kit number in this maintenance manual.
- 2) Verify the size of the valve the parts are to be used on.
- 3) Provide full model number located on I.D. plate.
- 4) Give kit number.
- 5) A serial number (located on the I.D. plate) will assist in ordering the proper kits.
- 6) Contact your local FEBCO Parts Distributor.

Troubleshooting

SYMPTOM #1	CAUSE:	SOLUTION:
Check fails to hold 1.0 psid minimum	A. Debris on sealing surfaces	Inspect and clean
	B. Leaking shutoff valve	Inspect and clean, or repair
	C. Damaged seat or seat disc	Disassemble and replace
	D. Spring stem not moving freely	Inspect for debris or damage

SYMPTOM #2	CAUSE:	SOLUTION:
Chatter during flow conditions	A. Worn or damaged parts	Inspect and replace

SYMPTOM #3 (DCDA ONLY)	CAUSE:	SOLUTION:
Low flow passing through the mainline valve (DCDA only)	A. Mainline check fouled	Inspect and clean, or repair
	B. Bypass plugged (DCDA only)	Inspect and clean

Vandalism

If the unit is installed where vandalism may be a problem, the assembly should be protected and secured. On ½" through 2" (15-20mm) units, the handles of shutoff valves can be removed to discourage tampering. On 2½" through 10" (65-250mm) units, a chain can be looped through both shutoff valve handwheels and locked in position to prevent tampering. Testcock handles can also be removed. On backflow prevention assemblies installed in conjunction with fire sprinkler systems, a tamper switch can be placed on the OS&Y shutoff valves that will trigger an alarm if an unauthorized closure should occur.

A protective enclosure can be installed over the unit to discourage vandals. If an enclosure is used, it should be installed so that adequate clearance is available for maintenance and testing. Consult local codes before installing any type of protective enclosure.

Testing

All mechanical devices should be inspected on a regular basis to ensure they are working correctly. The assembly should be tested at time of initial installation, after servicing or maintenance, and at least annually thereafter. Acceptable test procedures are published by Foundation for Cross-Connection Control and Hydraulic Research at the University of Southern California (USC), The American Water Works Association (AWWA), The American Society of Sanitary Engineering (ASSE Series 5000) and the Canadian Standards Association (CAN/CSA B64.10). Please consult the regulatory authority in your area for more specific information.

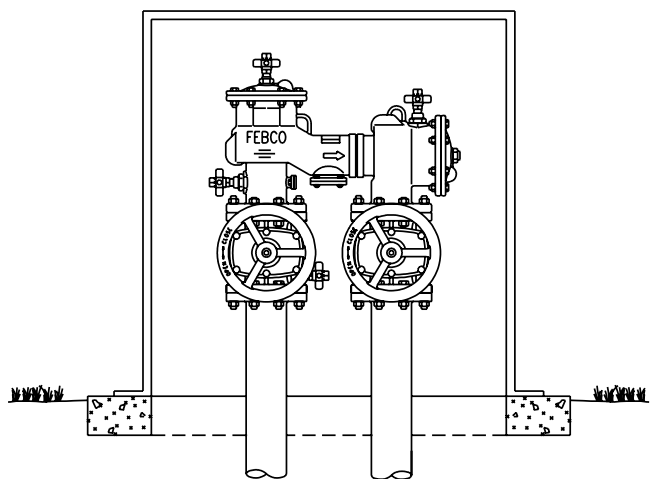

Freeze Protection

The Double Check Backflow Prevention Assembly may be subject to damage if the internal water is allowed to freeze. The unit must be protected from freezing using a heated enclosure, insulation using heat tape, or other suitable means. The unit must always be accessible for testing and maintenance. If the system will be shut down during freezing weather, use the following procedures to drain internal passages.

Ball Valve Shutoff Draining Procedure

If the assembly has been installed with ball valve shutoff valves, they must also be properly drained to prevent freeze damage. After draining procedure has been completed on the backflow prevention assembly, position all ball valve shutoffs and test cocks in a half open/half closed (45 degree) position.

Open the ball valve approximately 45 degrees while draining the pipeline and assembly to allow water between the ball valve and valve body to drain. Leave the ball valve in this position for the winter to prevent freeze damage.

The ball valve must be fully closed before the system is repressurized.
OPEN AND CLOSE BALL VALVES SLOWLY TO PREVENT DAMAGE TO THE SYSTEM CAUSED BY WATER HAMMER.

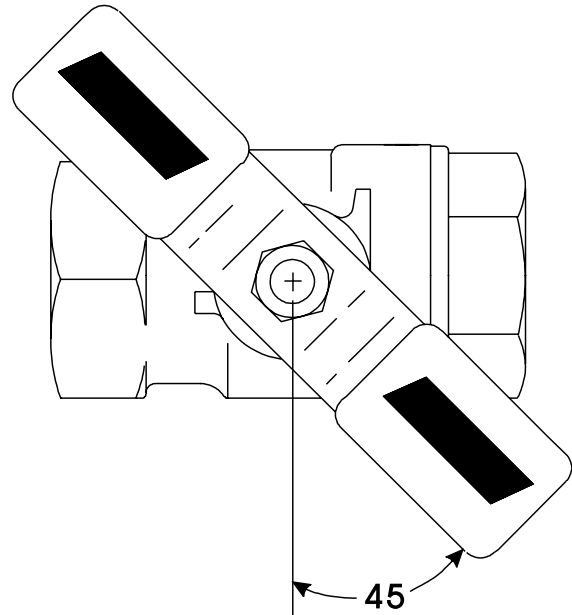

Main Valve Draining Procedure ½" - 2" (15-50mm)

1. Close the main shutoff valve.
2. Open the inlet drain.
3. Open the inlet and outlet ball valves 45 degree (half open, half closed).
4. Open all testcocks.
5. Open the outlet drain.
6. Remove the cover and inlet check module until all water inside valve drains back out through inlet drain.
7. If you "blowout" the piping downstream of the backflow assembly using compressed air:

Connect the air supply to the outlet drain and close the outlet ball valve. After clearing the system with air, partially open the outlet ball valve. Leave all drain valves, testcocks, and ball valves in half open/half closed position for the winter. (See above for more detailed instructions).

Main Valve Draining Procedure 2½" - 10" (65-250mm)

Slowly close supply valve within freeze protected area, open all test valves on the backflow preventer. For sizes 2½" - 10" (65-250mm), water within the zone between the two checks may be drained by loosening the bolts (Item 24) on the bottom cover plate (Item 19). (See Page 8).

All water will be drained from the inlet side and the zone between the two checks of the Series 870V. All water on the inlet side will be drained down to the No. 1 test cock on the Series 850. The remaining water on the inlet side may be drained to the lowest point on the Series 850 2½" - 10" (65-250mm) by removing the small (Item 36) bottom plate. (See Page 8). If you desire to add a drain plug, there is sufficient material for drilling and tapping ¼" IPS thread in the cover (Item 19); however, adding a drain plug is not necessary. Loosen the mounting nuts and bolt to allow drainage from beneath the plate.

The system design must provide a means for draining upstream of the #1 shutoff valve and downstream of the #2 shutoff valve.

Position the assembly shutoff valves and test cocks in the half open/half closed position to allow complete draining of the assembly shutoff valve bodies and test cocks. (See above).

General Service Procedures ½" - 10" (15-250mm)

1. FEBCO backflow prevention assemblies can be serviced with standard tools and are designed for ease of maintenance. The assemblies are designed to be serviced in line, so the unit should not need to be removed from the line during servicing. NO special tools are required.
2. The most common cause of check fouling is dirt and debris in the seating areas. The line should be flushed clean of debris before installation of the assembly. To flush the line after installation of the assembly, slowly close the inlet shutoff valve, remove the covers and spring assemblies of both check valves and open the inlet shutoff valve to allow sufficient flow of water through the assembly to clear all sand, debris, etc. from the line. If debris in the water continues to cause fouling, a strainer may be installed upstream of the assembly (check local codes).
3. Rinse all parts with clean water before reassembly.
4. Lubricant is recommended only for #2 check cover O-ring to help hold O-ring in place during reassembly (Series 870V and 876V). Apply a thin coating of the lubricant supplied in the repair kit to the O-ring groove in the #2 check body, and position the O-ring in the groove.
5. Carefully inspect seals and seating surfaces for damage or debris. If the check valve seat disc has been severely cut at the seat ring diameter, the assembly has been subjected to extremely high and repeated back pressure. Either thermal water expansion or water hammer are the most likely causes. If back pressure persists, consider installation of a pressure relief valve downstream of the assembly.
6. Use caution to avoid damaging any guiding surfaces while handling parts. Do not force parts together. The O-ring seals used in FEBCO assemblies require only a small tightening force to insure a positive seal.
7. Test unit after servicing in accordance with locally approved test methods to insure proper operation (See Page 5 for more details).
8. Refer to applicable parts lists and cut-a-ways (Pages 11-13) for visual aid information.

Service Procedures for Series 850, 856, 870V & 876V 2½"-10" (65-250mm)

Check Valve Disassembly and Reassembly

1. Spring Module Removal

- a. Slowly close outlet shutoff valve and inlet shutoff valve. Bleed residual pressure by opening #4, #3, and #2 test cocks (See Page 11 for test cock location).
- b. Remove cover bolts, removing the two bolts last that are located next to the retainer pin. Remove cover.

NOTE: Spring module is positioned in the body by the cover. Spring is captured in the module.
- c. Refer to Page 11-12. Remove pivot bearing (Item 13) from the upper spring retainer of the spring module. Inspect pivot bearing (Item 13) and bearing socket (Item 15). Small hole in bearing socket indicates replacement is required. Remove retaining clip (Item 5.1) from groove on one end of the load pin (Item 7). Hold spring module with one hand while sliding out load pin (Item 7) from arm (Item 4). Lift out spring module and inspect for wear or damage. Replace spring module if necessary.

2. Check Disk Removal

- a. Remove jam nut (Item 16) and washer (Item 17) from check disc stem threads. Lift the arm and remove the check disc (Item 6). Inspect sealing surface for debris or damage. Replace check disc if necessary.

NOTE: When jam nut (Item 16) is tight, check disc is designed to "wobble."

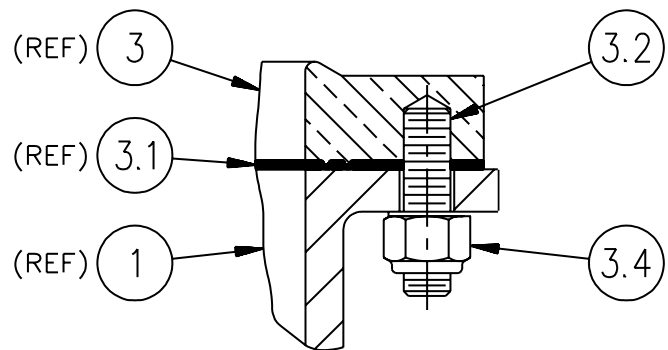

3. Seat Ring Assembly Removal

- NOTE:** Remove the seat ring assembly only if the seat ring (Item 3) or arm (Item 4) appear to be worn or damaged.
- a. Remove locknuts (Item 3.4). (See above drawing).
 - NOTE:** When reassembling, tighten locknuts to 40-50 in./lbs. If leaking occurs around bolt, further tighten until leaking stops. Do not over tighten.
 - b. Remove seat ring assembly.
 - c. Remove retaining clip (Item 5) from one end of the swing pin (Item 4.2). Hold arm (Item 4) while sliding out swing pin (Item 4.2). Inspect bushings (Item 4.1) and pin (Item 4.2) for wear or damage. Replace if necessary. Inspect gasket (Item 3.1) for debris and/or damage. Replace if necessary.
- NOTE:** Reverse the previous procedure to reassemble the components. Seat ring will only fit into body one way. Check alignment of seat ring if studs do not align with body holes. Gasket is also non-symmetric. Both seat ring and gasket have a notch that indicates non-symmetric hole. Clean all parts thoroughly with clean water before reassembly. Reassemble and bleed test cocks #4, and #3. Re-pressurize the assembly and test to ensure proper operation.

Repair Parts 850 / 856

2½" - 10" (65 - 250mm) Double Check / Double Check Detector Assemblies

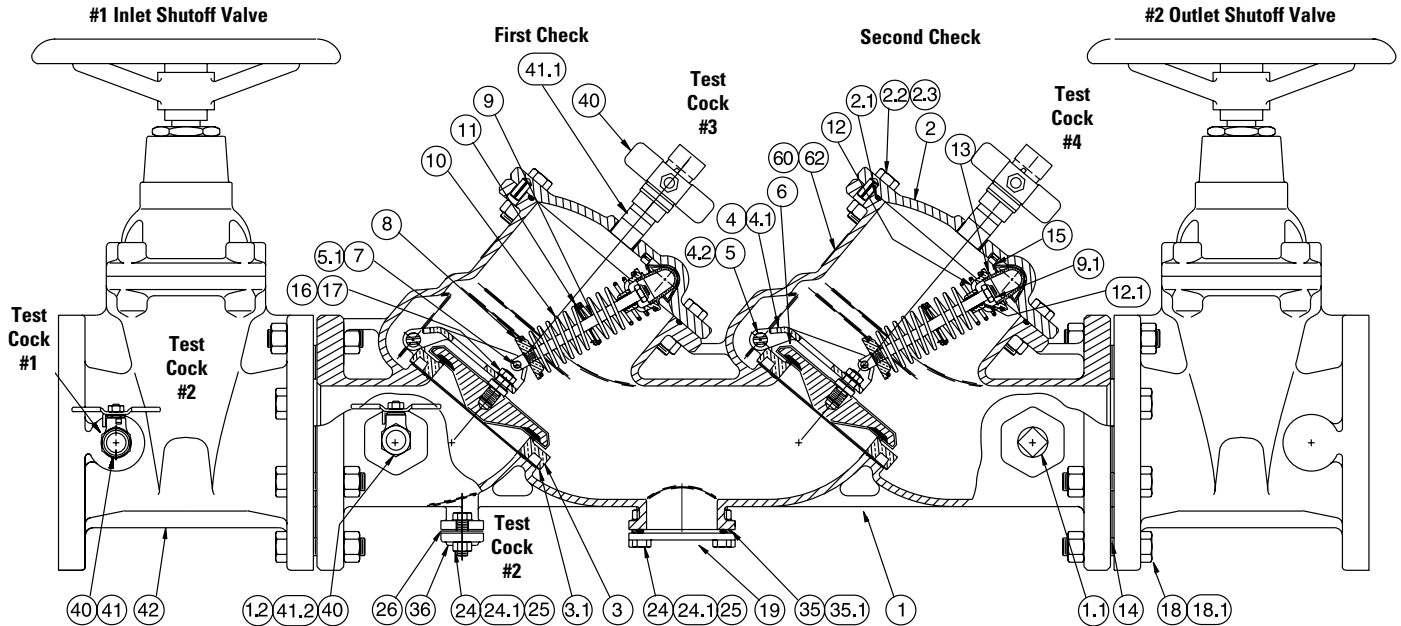

ITEM DESCRIPTION	STYLE	SIZE	2½" & 3" (65 - 80mm)	4" (100mm)	6" (150mm)	8" & 10" (200 - 250)
DISC ASSEMBLY Items 6, 16, 17	N-Shape Only	Part #	905182	905153	905154	905155
SINGLE SPRING MODULE Items 5.1, 7, 8, 9, 9.1, 10, 11, 12, 12.1	850	Part #	905142	905143	905144	905145
CHECK REPLACEMENT KIT Items 2.1, and 3 - 17	856	Part #	905147	905148	905149	905150
	850	Part #	905527	905534	905537	905539
SEAT RING / ARM ASSEMBLY Items 3, 3.1, 3.2, 3.4, 4, 4.1, 4.2, 5	856	Part #	905529	905536	905538	905541
	ALL	Part #	905157	905158	905159	905160
RUBBER PARTS KIT Items 2.1, 3.1, 6, 15, 26, 35, 35.1, 45, 45.1	ALL	Part #	905249	905163	905164	905165
COVER ASSEMBLY Items 2, 2.1, 15	With Bulkhead Fitting	Part #	905167	905168	905169	905170
	TAPPED	Part #	905376	905377	905378	905379
BULKHEAD FITTING FOR COVER* Items 43.1, 45.1, 46.1, 47.1	850	Part #	905275		905277	
	856	Part #	905275		905277	
BULKHEAD FITTING FOR BODY* Items 43, 45, 46, 47	850	Part #	905276		905277	
	856	Part #	905277			

*Bulkhead fittings are not furnished on late models. Very early productions of Series 856 may require a different bulkhead fitting. Consult your FEBCO representative for assistance.

Repair Parts 870, 870V / 876, 876V

2½" - 10" (65 - 250mm) Double Check / Double Check Detector Assemblies

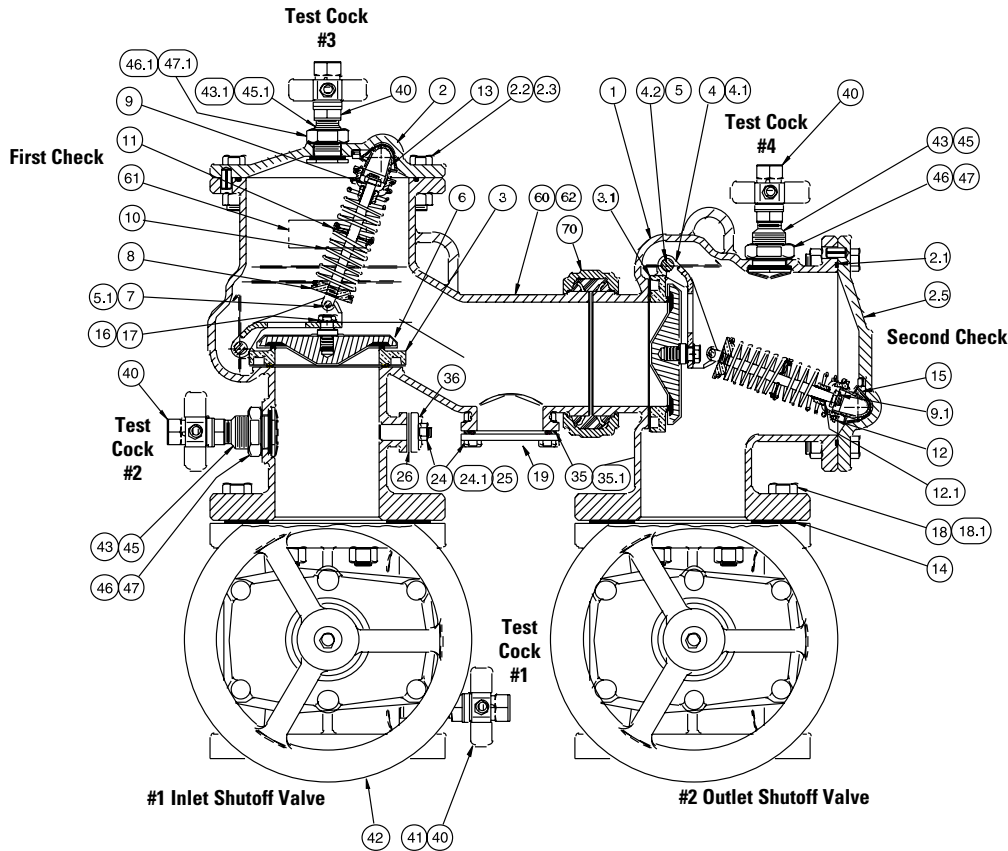

ITEM DESCRIPTION	STYLE	SIZE	2½" & 3" (65 - 80mm)	4" (100mm)	6" (150mm)	8" (200mm)	10" (250mm)
DISC ASSEMBLY Items 6, 16, 17 (10", Item 6 only)	ALL	Part #	905152	905153	905154	905155	400145
SINGLE SPRING MODULE Items 5.1, 7, 8, 9, 9.1, 10, 11, 12, 12.1	870, 870V	Part #	905142	905143	905144	905145	905146
	876, 876V	Part #	905147	905148	905149	905150	905151
CHECK REPLACEMENT KIT Items 2.1, and 3 - 17	870, 870V	Part #	905528	905534	905537	905539	905540
	876, 876V	Part #	905530	905536	905538	905541	905542
SEAT RING / ARM ASSEMBLY Items 3, 3.1, 3.2, 3.4, 4, 4.1, 4.2, 5	ALL	Part #	905157	905158	905159	905160	905161
RUBBER PARTS KIT Items 2.1, 3.1, 6, 15, 26, 35, 35.1, 45, 45.1	ALL	Part #	905162	905163	905164	905165	905166
COVER ASSEMBLY (Inlet Check)* Items 2, 2.1, 15	ALL	Part #	905167	905168	905169	905170	905171
COVER ASSEMBLY (Outlet Check)* Items 2, 2.1, 15	ALL	Part #	905244	905245	905246	905247	905248
BULKHEAD FITTING FOR COVER* Items 43.1, 45.1, 46.1, 47.1	870, 870V	Part #	905275			905277	
	876, 876V	Part #	905275			905277	
BULKHEAD FITTING FOR BODY* Items 43, 45, 46, 47	870, 870V	Part #	905276			905277	
	876, 876V	Part #	905277				

*Bulkhead fittings are not furnished on late models. Very early productions may require a different bulkhead fitting. Consult your FEBCO representative for assistance.

Service Procedures for Series 805YB — ¾" Bypass

1. Bypass Check Valve Inspection/Repair Series 805YB ¾".
 - a. Close inlet and outlet shutoff valves. Bleed residual pressure by opening first the #4 test cock, then the #3 and #2 test cocks.
 - b. Unscrew cap using appropriate size wrench. NOTE: Cap is spring loaded.
 - c. Remove the spring and disc holder assembly.
 - d. Inspect guiding bore of the cap and poppet stem for any buildup of calcium or other mineral deposits. If this condition exists, it may be removed with the careful use of a 5/8" (.6250) reamer or a thin blade knife.
 - e. Check disc holder and stem movement in the guide to insure they move freely. Debris can inhibit proper movement.
2. Check Valve Seat Disc Replacement Series 805YB (¾").
 - a. Hold disc holder assembly in one hand and remove screw and disc washer.

CAUTION: The use of pliers or other tools may damage the guiding surfaces and require unnecessary replacement.
Do not scratch or mark sealing or guiding surfaces.
 - b. Inspect seat disc for wear or cuts. Remove old seat disc and replace. Disc may be turned over for temporary repair until a new disc is available.
 - c. If the seat disc has been severely cut along the seat ring diameter, the assembly is being subjected to extremely high back pressure from thermal water expansion, water hammer or other causes of excessive water pressure. Seat discs damaged in such a manner should be replaced and not turned over to be reused.
3. Check Seat Ring Replacement
 - a. The seat rings are threaded into the body with an O-ring seal against the body. Remove only if the sealing edge is damaged. Using an inside pipe wrench (1-inch IPS size), grip the inside surface of the seat ring and loosen the part.
 - b. Unscrew the seat ring/O-ring and discard.
 - c. Using lubricant supplied with the repair kit, apply a thin coating of lubricant to the O-ring surface and position the O-ring on the seat ring.
 - d. Thread the seat ring/O-ring into the body until the O-ring is compressed and the seat ring contacts the body. DO NOT TORQUE BEYOND "HAND TIGHT".
4. Check Valve Reassembly Series 805YB (¾") .
 - a. Position the disc in the cleaned holder and retain with disc washer and screw.
 - b. Position the spring around the centering ring of the disc holder and reinsert the disc holder assembly into the check body.
 - c. Apply a thin coating of petroleum jelly (food grade) on the O-ring in the cap and thread cap onto the check valve body using the appropriate sized wrench.
 - d. Close the #4, #3, and #2 test cocks and slowly open first the inlet and then outlet shutoff valves and return the assembly to service.
 - e. Test the assembly to insure it is operating properly.

Repair Parts 805YB and Bypass

ITEM	DESCRIPTION	MATERIALS
1	Body	Bronze
7	Cap	Bronze
8	O-ring	Buna-N
9	Disc Holder	Acetal
10	Seat Disc	Nitrile
11	Washer	Stainless Steel
12	Screw	Stainless Steel
13	Spring	Stainless Steel
30	Test Cock	Bronze
35	Seat Ring	Bronze
36	O-ring	Buna-N
40	Ball Valve	Bronze
40.1	Ball Valve	Bronze
40.2	Ball Valve w/tap	Bronze
40.3	Test Cock	Bronze

ITEM	DESCRIPTION	MATERIALS
300	Water	Meter
301	Nipple	Brass
302	Nipple	Brass
303	Nipple	Brass
305	Nipple	Brass
309	Elbow	Bronze
311	Elbow	Bronze
312	Fitting	Bronze
314	Fitting	Bronze
315	Tee	Brass
316	Elbow	Copper
317	805YB-3/4"	
Part No. 905-042	805YB Rubber Repair Kit	
Part No. 905-044	805 YB Check Assembly	
Part No. 905-280	805 YB Seat Ring Kit	

Series 876V Bypass

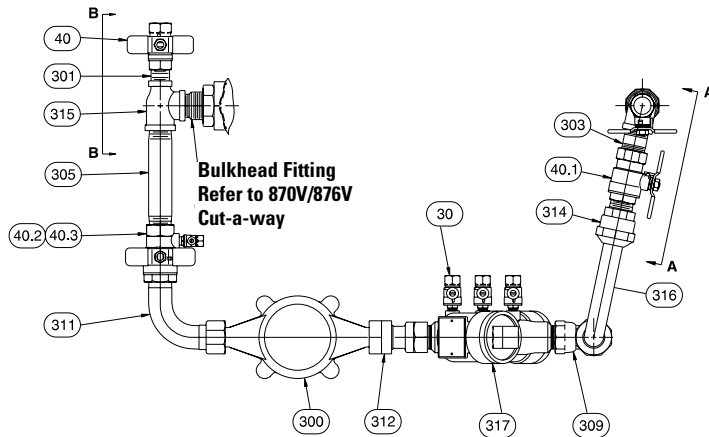

Series 856 Bypass

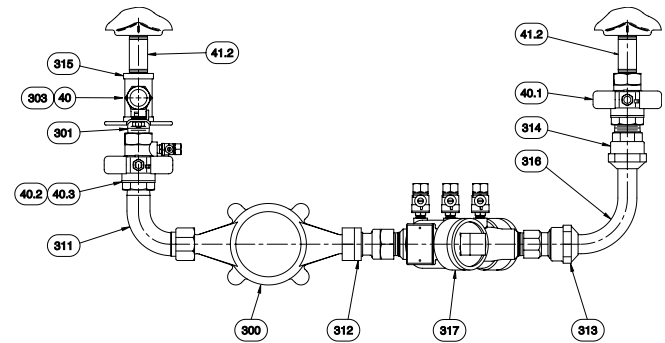

VIEW A-A
(Top of 2nd check)

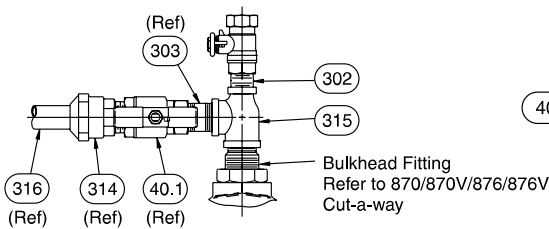

VIEW B-B
(Inlet side of valve)

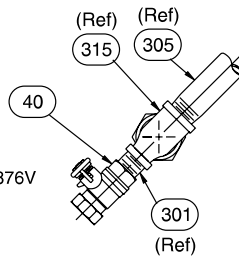

805YB

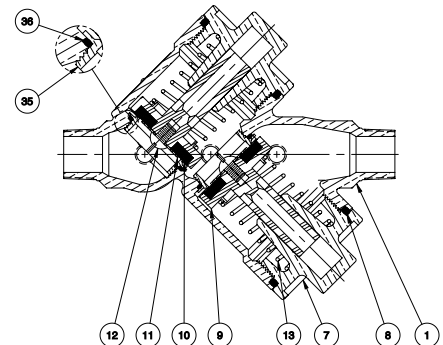

FEBCO Performance, Value and Quality

FEBCO MasterSeries® 2½" - 10" (65-250mm)

	Double Check Assembly	Double Check Detector Assembly	Reduced Pressure Assembly
"N" - Shape	<p>Series 870V</p>	<p>Series 876V</p>	<p>Series 880V</p>
Vertical	<p>Series 870V</p>	<p>Series 876V</p>	<p>Series 880V</p>
Conventional In-Line	<p>Series 850</p>	<p>Series 856</p>	<p>Series 860</p>

For nearly half a century, customers have looked to FEBCO for quality products, reliable low head-loss performance, and great value. Today, with the new FEBCO MasterSeries® designs, FEBCO has once again taken the initiative with patented product innovations.

All 2½ through 10" (65-250mm) MasterSeries® products include:

- Patented VectorCheck performance for low head loss
- Cast ductile iron bodies for lighter weight
- Lowest installed cost — Saves on labor and material
- Choice of cost-saving "N"-Shape designs, revolutionary vertical designs, or conventional in-line designs.

Contact a FEBCO representative today for product literature and technical specifications on FEBCO MasterSeries® backflow prevention products.

For additional information, visit our web site at: www.FEBCOonline.com

CALIFORNIA PROPOSITION 65 WARNING

WARNING: This product contains chemicals known to the State of California to cause cancer and birth defects or other reproductive harm. (California law requires this warning to be given to customers in the State of California.)

For more information: www.watts.com/prop65

Limited Warranty: FEBCO warrants each product to be free from defects in material and workmanship under normal usage for a period of one year from the date of original shipment. In the event of such defects within the warranty period, the Company will, at its option, replace or recondition the product without charge.

THE WARRANTY SET FORTH HEREIN IS GIVEN EXPRESSLY AND IS THE ONLY WARRANTY GIVEN BY THE COMPANY WITH RESPECT TO THE PRODUCT. THE COMPANY MAKES NO OTHER WARRANTIES, EXPRESS OR IMPLIED. THE COMPANY HEREBY SPECIFICALLY DISCLAIMS ALL OTHER WARRANTIES, EXPRESS OR IMPLIED, INCLUDING BUT NOT LIMITED TO THE IMPLIED WARRANTIES OF MERCHANTABILITY AND FITNESS FOR A PARTICULAR PURPOSE.

The remedy described in the first paragraph of this warranty shall constitute the sole and exclusive remedy for breach of warranty, and the Company shall not be responsible for any incidental, special or consequential damages, including without limitation, lost profits or the cost of repairing or replacing other property which is damaged if this product does not work properly, other costs resulting from labor charges, delays, vandalism, negligence, fouling caused by foreign material, damage from adverse water conditions, chemical, or any other circumstances over which the Company has no control. This warranty shall be invalidated by any abuse, misuse, misapplication, improper installation or improper maintenance or alteration of the product.

Some States do not allow limitations on how long an implied warranty lasts, and some States do not allow the exclusion or limitation of incidental or consequential damages. Therefore the above limitations may not apply to you. This Limited Warranty gives you specific legal rights, and you may have other rights that vary from State to State. You should consult applicable state laws to determine your rights. **SO FAR AS IS CONSISTENT WITH APPLICABLE STATE LAW, ANY IMPLIED WARRANTIES THAT MAY NOT BE DISCLAIMED, INCLUDING THE IMPLIED WARRANTIES OF MERCHANTABILITY AND FITNESS FOR A PARTICULAR PURPOSE, ARE LIMITED IN DURATION TO ONE YEAR FROM THE DATE OF ORIGINAL SHIPMENT.**



A Division of Watts Water Technologies, Inc.

USA: 4381 N. Brawley • Ste. 102 • Fresno, CA • 93722 • Tel. (559) 441-5300 • Fax: (559) 441-5301 • www.FEBCOonline.com
Canada: 5435 North Service Rd. • Burlington, ONT. • L7L 5H7 • Tel. (905) 332-4090 • Fax: (905) 332-7068 • www.FEBCOonline.ca

IOM-F-DC/DCDA 0845

EDP# 1915984

© FEBCO, 2008